

0.4 mm differential membrane hydrophone (D1604)



The 0.4 mm differential membrane hydrophone is one of a range of membrane hydrophones manufactured by Precision Acoustics Ltd. It is designed to be used in conjunction with its own dedicated power supply to form a hydrophone system. Whenever properties are reported in this data sheet they refer to those of a hydrophone system incorporating a 0.4 mm differential membrane hydrophone and power supply.

The size of the active element of a hydrophone affects many properties including sensitivity, frequency response, directional response, dynamic range and noise equivalent pressure. This technical data sheet is prepared in compliance with IEC 62127 – part 3 [3] and provides a detailed specification of a 0.4 mm differential membrane hydrophone system.

The 0.4 mm differential membrane hydrophone is a gold-standard measurement device specifically designed to offer high sensitivity and broad frequency response for a wide range of applications at frequencies from 1.0 MHz to 40 MHz, especially diagnostic ultrasound.

PRODUCT DESCRIPTION

The 0.4 mm differential membrane hydrophone is a gold-standard hydrophone that provides excellent sensitivity, frequency response, directional response, dynamic range and noise equivalent pressure for measurements in the 1 MHz to 40 MHz range. The 0.4mm active area provides sufficient sensitivity that signals ≈ 1 kPa can be measured. However larger sensor areas result in a more directional response pattern particularly at higher frequencies, and 0.2mm differential membrane hydrophones are also available. For very high frequency application (> 40 MHz) a differential membrane hydrophone based upon 12 μm PVDF film is also available

Hydrophone Specification

Model Number	D1604	
Sensor element dimensions	Diameter:	0.4 mm
	Film thickness:	16 μm
Hydrophone dimensions	See Figure 1	
Weight of hydrophone	70 g (without cable) 160 g (with cable)	
Transduction method	Piezoelectric conversion	
Sensor material	Polyvinylidene Fluoride (PVDF)	
Mean sensitivity in the range 2 to 20 MHz	340 mV/MPa (additional data below)	
Device-to-device variation	± 3 dB	
Hydrophone frequency band	0.1 MHz to 40 MHz	
Measurement uncertainty (typical of National Measurement Institution calibration)	0.1 MHz to 1 MHz:	8 %
	1 MHz to 8 MHz:	9 %
	9 MHz to 20 MHz:	11 %
	21 MHz to 30 MHz:	12 %
	31 MHz to 40 MHz:	15 %
Output impedance of hydrophone system	50 Ω	
Orientation during use	Membrane surface orthogonal to the acoustic axis of the source (see Figure 4)	

Power Supply Specification

Model Number	DPSU	
AC supply voltage	Wide range input:	100/120V at 60Hz or 230/240V at 50Hz AC, 20 mA. (switchable)
Input impedance	50 Ω	
Output impedance	50 Ω	
Power consumption	2.4 W	
Operating temperature range	0 $^{\circ}\text{C}$ to 50 $^{\circ}\text{C}$	
Terminations	Custom 5-way connector (input) BNC (output)	
Maximum dimensions	185 mm (length) 109 mm (width) 45 mm (height)	
Weight	925 g	

Dimensions

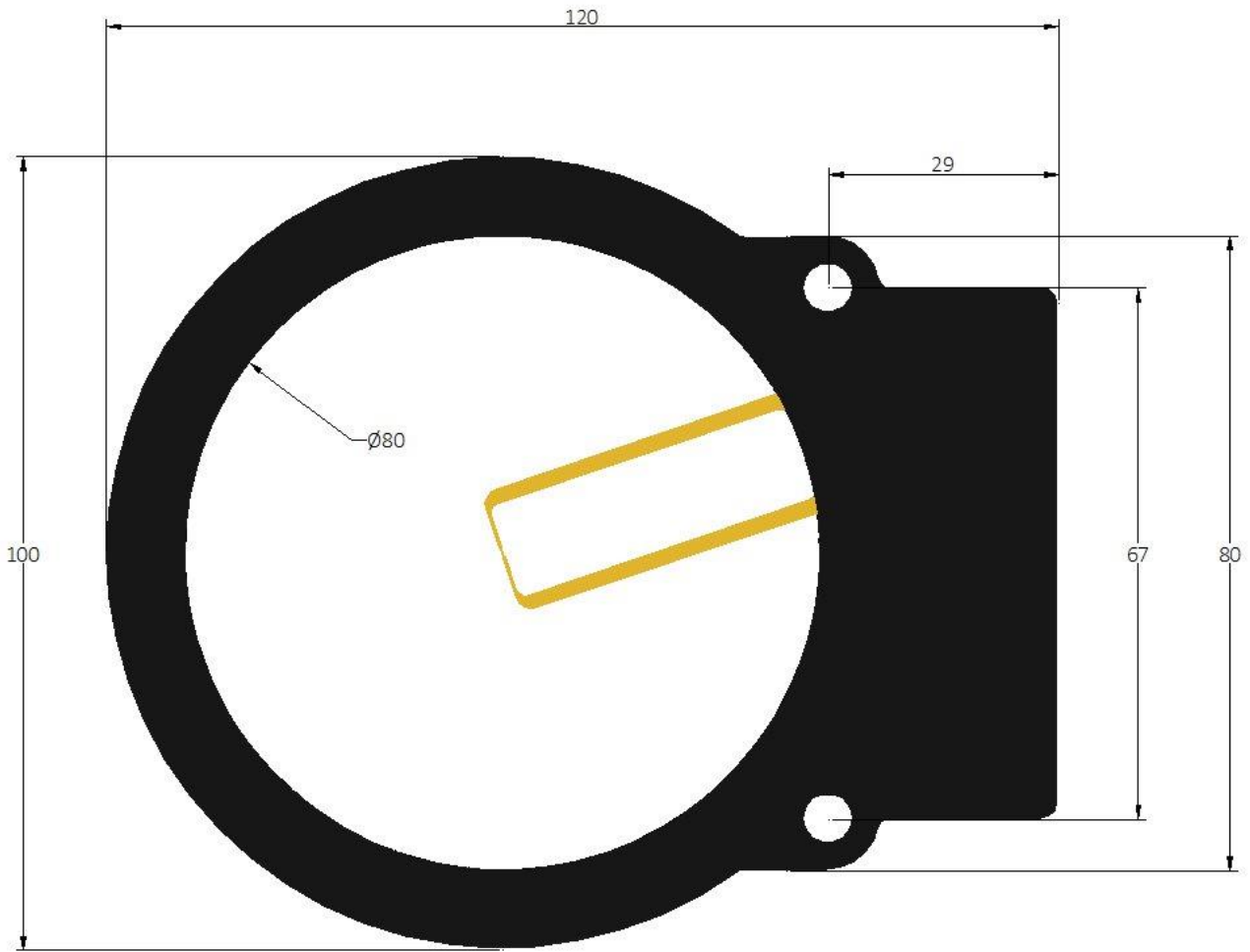

Figure 1 - Dimensioned drawing of 0.4 mm differential membrane hydrophone (D1604)

SENSITIVITY AND FREQUENCY RESPONSE

All hydrophones have a frequency response that varies as a function of frequency. The theoretical basis of this response is well understood and described elsewhere [1] [2]. Figure 2 and Figure 3 show the typical end-of-cable loaded sensitivity for the membrane hydrophone when loaded by $50\ \Omega$. Figure 3 also displays the phase response of the membrane hydrophone over the frequency range 1 MHz to 40 MHz. The data displayed in these figures was acquired by the National Physical Laboratory, London (NPL).

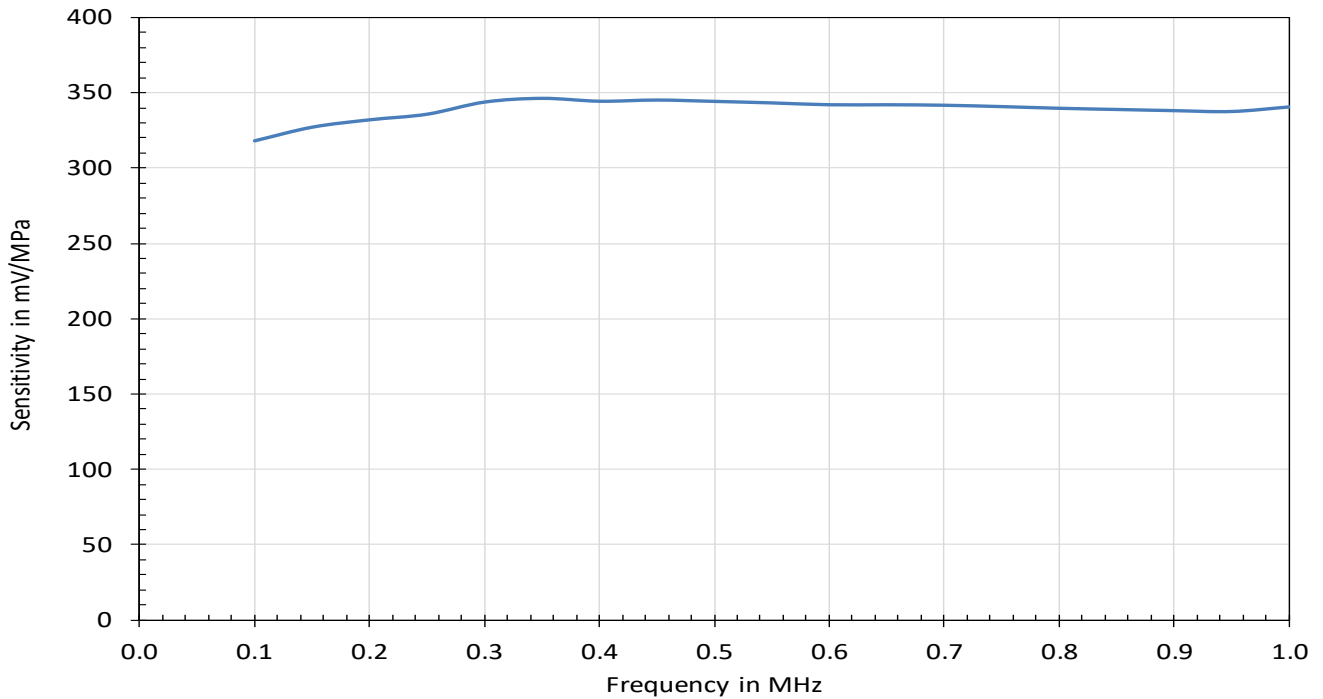

Figure 2 – Typical frequency response of a 0.4 mm differential membrane hydrophone in the range 100 kHz to 1.0 MHz

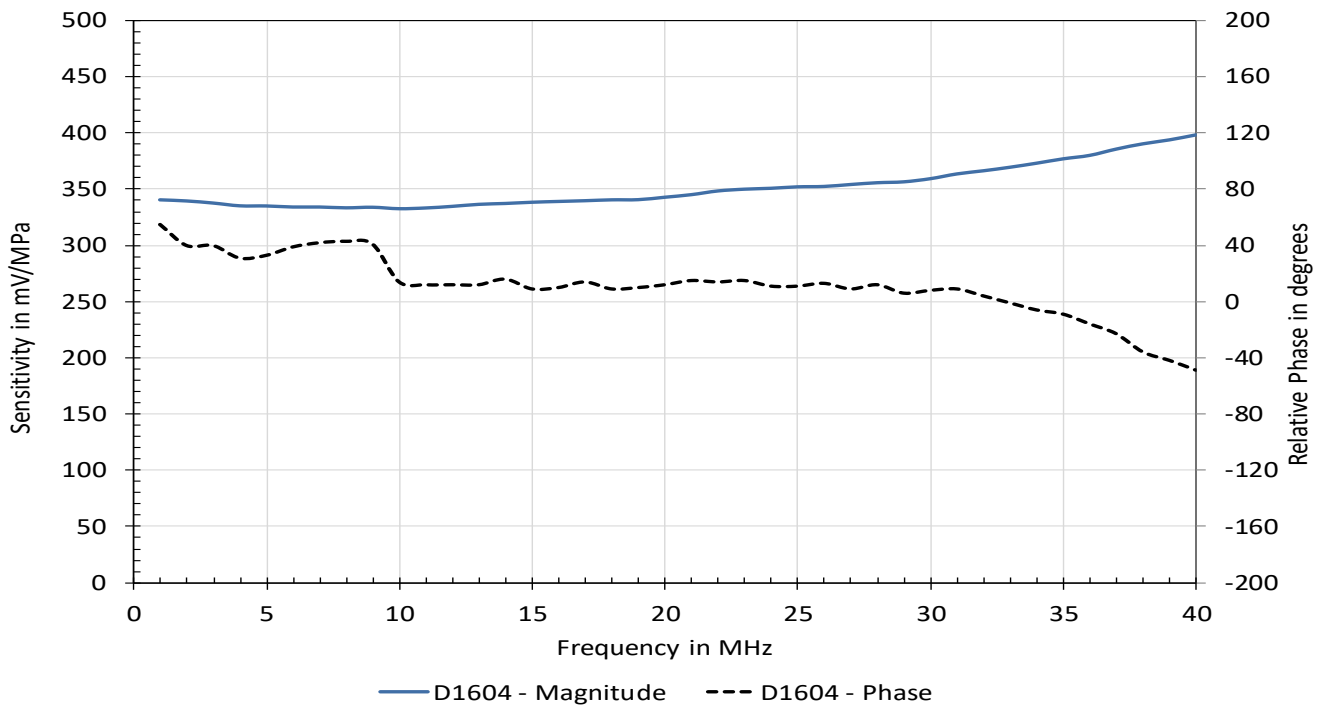

Figure 3 – Typical frequency response of a 0.4 mm differential membrane hydrophone in the range 1.0 MHz to 40 MHz

Hydrophones used to make absolute measures of acoustic pressure should be calibrated at least once every 12 months. The hydrophone should be checked against a reference source on a monthly basis so that variations in sensitivity are identified sooner than the annual calibration interval.

The measurement uncertainty for the frequency response measurement was determined in accordance with the methods established in [3]. One of the main uncertainty contributions is that due to the calibration of the reference hydrophone used in the calibration, which itself is traceable to national primary standards.

DIRECTIONAL RESPONSE

Membrane hydrophones have been previously shown [4] to have a directional response that has large side lobes at low frequencies and large angles. This is a very different form to that normally expected of probe type hydrophones and is attributed to the presence of Lamb waves on the membrane.

The directional response of the hydrophone was established using the same nonlinear field as that used in the determination of the frequency response. The hydrophone was placed in a mounting fixture that permitted the precise position of the active element to be adjusted. The hydrophone was then adjusted so that there was less than 100 ns temporal shift of the recorded waveform when it was rotated in the field. This alignment ensured that the hydrophone was not displaced during rotation and therefore that any variations in received signal were due only to the directional response of the hydrophone. By recording the

waveform generated by the hydrophone as a function of angle, the directional response at a range of frequencies could be established. The directional response of the 0.4 mm differential membrane hydrophone at 1 MHz, 5 MHz, 10 MHz, 15 MHz, 20 MHz, 25 MHz, 30 MHz and 40 MHz has been plotted in Figure 5.

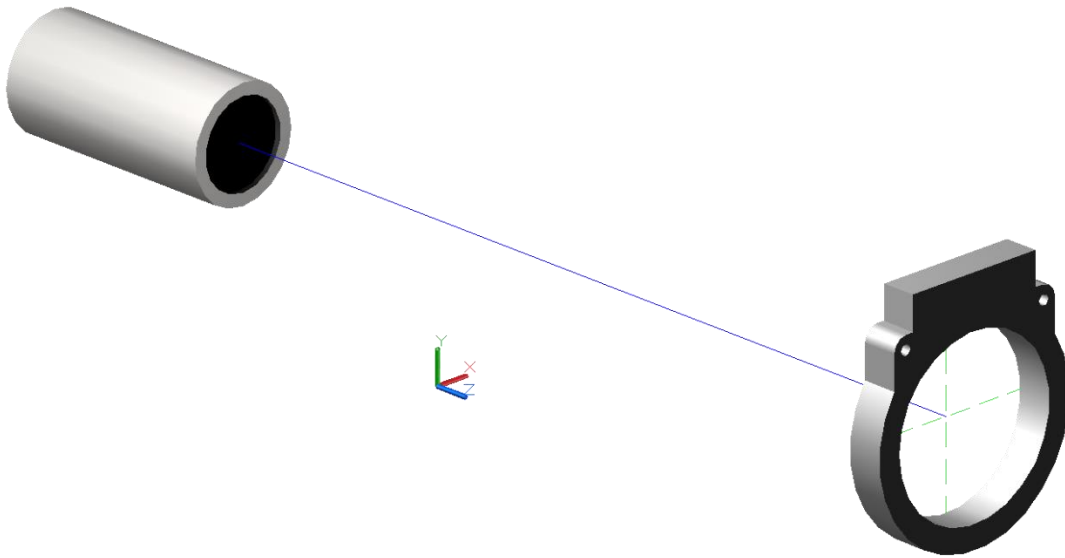

Figure 4 - Orientation of membrane hydrophone during use

Figure currently unavailable

Figure 5 - Directional response of 0.4 mm differential membrane hydrophone

Effective radius

The effective radius of the hydrophone was calculated from the angles at which the -3 dB and -6 dB points of a directional response curve occur in accordance with the methods described in [5] and the mean effective radius is shown in Figure 6. However, the IEC method fails at lower frequencies for this hydrophone because it is based upon a theoretical model



Figure currently unavailable

that fails to account for Lamb wave propagation and the directional response stays above -6 dB level at frequencies below 5 MHz.

Figure 6 – Effective radius of 0.4 mm differential membrane hydrophone

DYNAMIC RANGE, LINEARITY AND ELECTROMAGNETIC INTERFERENCE

Lower dynamic limit

The noise floor of the hydrophone assembly limits the measurement of small acoustic signals. The noise level of the internal pre-amplifier is approximately 200 μV rms over a 100 MHz bandwidth. If the hydrophone sensitivity is assumed to be 340 mV/MPa, the noise level stated leads to a noise equivalent pressure for the 0.4 mm differential membrane hydrophone

$$\frac{200 \mu\text{V}}{340 \text{ mV} / \text{MPa}} = 0.6 \text{ kPa}$$

The data acquisition system being used to record the waveforms produced by the hydrophone can also limit the minimum recordable signal. For example, an oscilloscope that is limited to a maximum resolution of 0.5 mV will only be able to display signals of amplitude $0.5 \text{ mV} / 340 \text{ mV/MPa} = 1.5 \text{ kPa}$ or greater.

$$\frac{0.5 \text{ mV}}{340 \text{ mV} / \text{MPa}} = 1.5 \text{ kPa}$$

Upper dynamic limit

Concerning the pressure threshold above which mechanical damage occurs to the hydrophone: this hydrophone has been designed to withstand ultrasonic pressures up to 10 MPa. Although hydrophones of this type have been used for ultrasonic fields that exceed 50 MPa, there is an elevated risk of damage. The supplier's advice should be sought if the hydrophone is to be used in fields containing acoustic pressure levels beyond 10 MPa.

Concerning the pressure beyond which amplifier saturation occurs: the pre-amplifier that is used with this hydrophone can start to exhibit nonlinearities when its output voltage exceeds a 3 V peak to peak. Taking into account the typical 0.4 mm differential membrane hydrophone sensitivity, this corresponds to a pressure of

$$\frac{3000 \text{ mV}}{340 \text{ mV} / \text{MPa}} = 8.8 \text{ MPa}$$

If ultrasonic pressures higher than this level are anticipated, a lower sensitivity differential membrane hydrophone (e.g. 0.2mm diameter active element) should be considered as these have a much higher saturation threshold.

ELECTRIC OUTPUT CHARACTERISTICS

No representative data are available here as this has not been determined for the hydrophone described here.

ENVIRONMENTAL ASPECTS

Temperature variation

This hydrophone can be used for measurement over an operating temperature range of 5 °C to 50 °C and can be stored over the range 5 °C to 50 °C. Exposure to temperatures above 60 °C has the potential to cause irreversible damage to the hydrophone.

This hydrophone assembly has been calibrated at a temperature between 19 °C and 25 °C. The sensitivity of the hydrophone will be a function of temperature and an increase in the sensitivity of 0.4 % per degree temperature rise should be expected.

Water quality

The hydrophone assembly has been designed for complete immersion in water and can easily withstand the hydrostatic pressure caused by 2 m of water. Although the hydrophone assembly can be used for prolonged periods (>48 h) of immersion, the hydrophone should be withdrawn from water and allowed to dry whenever it is not in use.

The 0.4 mm differential membrane hydrophone is designed for use within de-ionised water. If the hydrophone is used in water with conductivity above 5 $\mu\text{S}/\text{cm}$ there can be changes to waveform shape arising from electrical capacitance effects through the water; this can be particularly noticeable on the peak negative excursion of the pressure waveform. Furthermore, hydrophone measurements standards such as the [6] [7] may have specific requirements for water quality.

Prolonged immersion in water that has not been deionized (e.g. tap water) can lead to a build-up of deposits on the hydrophone. Calcium carbonate deposits can be a particular problem in "hard" water areas and will lead to a loss of sensitivity of the hydrophone.

Other liquid media

Although designed for operation in water, the hydrophone assembly can be used in many other liquid media. It should be noted, however, that the calibration of this hydrophone was undertaken in water. Other materials present different acoustic impedance loads on the hydrophone active element and this is likely to affect the sensitivity of the hydrophone. Certain liquids should be avoided due to their chemically aggressive nature. Examples of materials that should be avoided are:

- concentrated acids (e.g. nitric acid, sulphuric acid);
- concentrated alkalis (e.g. sodium hydroxide);
- strong organic solvents [e.g. many aldehydes, many ketones, Dimethyl Chloride (DMC), dimethylformamide (DMF)].

As supplied, the only materials of the hydrophone assembly that are exposed to the surrounding liquid are gold, ABS, PVDF and the polyvinyl chloride (PVC) cladding on the pre-amplifier cable.

REFERENCES

- [1] P. Gelat, R. Preston and A. Hurrell, "A theoretical model describing the transfer characteristics of a membrane hydrophone and validation," *Ultrasonics*, vol. 43, pp. 331-341, 2005.
- [2] S. Robinson, R. Preston, M. Smith and C. Millar, "PVDF Reference Hydrophone Development in the UK—From Fabrication and Lamination to Use as Secondary Standards," *IEEE Trans. UFFC*, vol. 47, pp. 1336-1344, 2000.
- [3] BIPM, *JCGM100: 2008 Evaluation of measurement data – Guide to the expression of uncertainty in measurement*, 2008.
- [4] D. R. Bacon, "Characteristics of a PVDF membrane hydrophone for use in the range 1-100 mhz," *IEEE Trans. SU*, Vols. SU-29, pp. 18-25, 1982.
- [5] IEC, *62127 Ultrasonics – Hydrophones – Part 3: Properties of hydrophones for ultrasonic fields up to 40 MHz*, 2007.
- [6] IEC, *62127 Ultrasonics – Hydrophones – Part 1: Measurement and characterisation of medical ultrasonic fields up to 40 MHz*, 2013.
- [7] IEC, *61157 Standard means for the reporting of the acoustic output of medical diagnostic ultrasonic equipment*, 2013.

All information is based on results gained from experience and tests, and is believed to be accurate but is given without acceptance of liability for loss or damage attributable to reliance thereon as conditions of use lie outside the control of Precision Acoustics Ltd.