

PVDF PROPERTIES and USES

CONTENTS

Contents	1
Introduction.....	3
Definitions.....	4
Properties of poled piezo-electric film	4
Piezo-electric Properties of PVDF and P(VDF-TrFE) Co-Polymer	5
Electrical Properties.....	5
Chemical Properties.....	5
Tips for the use of PVdF.....	11
General information	11
Attaching Electrodes to PVDF.....	11
General Discussion.....	11
Conductive Adhesive-Type Solutions	12
Mechanical Contact Solutions	12
Specifics for Bi-Morph configuration.....	13
Electrode attachment.....	13
Items required	13
Method	13

INTRODUCTION

The process of turning PVDF from an inert polymer to a poled piezo-electric film is a complicated one involving several changes. Partly due to this, and partly due to the inherent randomness of the semi-amorphous structure of PVDF, there can be considerable variation in the material properties of the final material. Consequently, the materials properties listed below provide an indication of the typical values, rather than any guarantee of exact data.

DEFINITIONS

The thickness axis of the film is numbered "3". Its other axis are noted "1" (machine direction during extrusion of the non-polar film) and "2" (transverse/across direction). We usually consider the following piezo and pyro coefficients:

- d_{3j} (in C/N) indicates the piezo activity of the film. It corresponds to the electrical charge delivered by 1m² of material when exposed to a pressure of 1Pa in "j" direction. It also gives the mechanical strain observed $\left(\frac{\Delta x_j}{x_j} \right)$ when an electrical field of 1V/m is applied.
- If the film is used in hydrostatic environment (equal pressure on all surfaces), $d_h = d_{31} + d_{32} + d_{33}$ is the appropriate piezo-coefficient to consider.
- g_{3j} (in V.m/N) indicates the electrical field created when a stress of 1Pa is applied along the "j" axis. The g and d coefficients are related through the equation, $g_{3j} = \frac{d_{3j}}{\epsilon}$.

PROPERTIES OF POLED PIEZO-ELECTRIC FILM

PHYSICAL PROPERTIES OF PVDF

Description	Semi-crystalline polymer consisting of crystallites embedded within amorphous polymer chains	
Density	ρ	1780 kg/m ³
Melting Temperature	T_m	175-180 deg C
Glass Transition Temperature	T_g	-42 °C
Curie Temperature	T_c	None observed but extrapolates to 205 deg C
Young's Modulus	E	8.3 GPa
Bulk Modulus	K	4.3 GPa
Shear Modulus	U	3.5 GPa
Poisson's Ratio	ν	0.18
Longitudinal Velocity	c_L	2250 m/s
Shear Velocity	c_S	1410 m/s
Refractive index	n	1.42

PIEZO-ELECTRIC PROPERTIES OF PVDF AND P(VDF-TRFE) CO-POLYMER

Piezo Strain Constant (shear mode direction 1)	d_{31}	Uniaxial Film: 22 pC/N Bi-axial Film: 6 pC/N Copolymer: 7-8 pC/N
Piezo Strain Constant (shear mode direction 2)	d_{32}	Uniaxial Film: 3 pC/N Bi-axial Film: 5 pC/N Copolymer: 7-8 pC/N
Piezo Strain Constant (thickness mode)	d_{33}	Uniaxial Film -30 pC/N Bi-axial Film: -30 pC/N Copolymer: -33/34 pC/N
Maximum usable temperature		Uniaxial Film: 75-80 deg C Bi-axial Film: 75-80 deg C Copolymer : 110 deg C

ELECTRICAL PROPERTIES

Coercive Field Strength	E_c	50-80 MV/m
Breakdown Field Strength	E_B	200 MV/m
Relative Dielectric Constant	ϵ_r	10-12

CHEMICAL PROPERTIES

Water Absorption < 0.02%

KEY TO TABLE

+	resistant
o	conditionally resistant
-	not resistant
+/o	resistant to conditionally resistant
o/-	conditionally resistant to not resistant

Medium	Concentration (%)	Temperature(°C)	Term	Resistance
Acetaldehyde	technically pure	23	7 days	-
Acetic acid	50	<=125	7 days	+
Acetic acid	50	<=150	7 days	0
Acetic acid	100	23	7 days	+
Acetone	technically pure	23	7 days	-
Allyl chloride		<=100	7 days	+
Ammonium hydroxide	30	<=150	7 days	+
Ammonium sulphate	50	<=150	7 days	+
Amyl acetate	technically pure	<= 50	7 days	+
Amyl alcohol	technically pure	<=150	7 days	+
Aniline	technically pure	<= 40	7 days	+
Benzaldehyde		23	7 days	-
Benzene	technically pure	23	7 days	+
Benzene	technically pure	50	7 days	0
Benzine regular		<=135	7 days	+
Benzine/benzene mixture		<=135	7 days	+
Benzoic acid	saturated	<=125	7 days	+
Borax	50	<=150	7 days	+
Brake fluid		<= 60	7 days	+
Bromine		<=100	7 days	+
Butane		23	7 days	+
Butanol		<= 75	7 days	+
Butanol		<=125	7 days	+

Medium	Concentration (%)	Temperature(°C)	Term	Resistance
Calcium hydroxide		<=135		+
Calcium hypochlorite		<= 95		+
Carbon dioxide	100	<=135	7 days	+
Carbon disulphide	100	23	7 days	+
Carbon tetrachloride	technically pure	<=150	7 days	+
Chlorine, gas		<=100	7 days	+
Chlorine, gas		<=125	7 days	0
Chlorine, liquid		<= 95	7 days	+
Chlorobenzene		<= 50	7 days	+
Chlorobenzene		<= 75	7 days	0
Chloroform	technically pure	<= 50	7 days	+
Chromic acid	<= 40	<= 80		+
Chromic acid	50	<= 50		+
Citric acid	50	<=150	7 days	+
Copper sulphate	50	<=150	7 days	+
Cyclohexane		<=150	7 days	+
Cyclohexanol		<= 65		+
Cyclohexanone		23		-
Decahydronaphthalene	technically pure	<=100	7 days	+
Detergents	ready-to-use	100	7 days	+
Diethylether		23	7 days	+
Dimethylformamide	technically pure	23		-
Dioxane		23		-
Ethanol	96 (Vol.)	<=100	7 days	+

Medium	Concentration (%)	Temperature(°C)	Term	Resistance
Ethyl acetate	technically pure	23	7 days	+
Ethyl acetate	technically pure	50		-
Ethylene glycol		<=150	7 days	+
Formaldehyde	37	<= 50	7 days	+
Formic acid	98	<= 75	7 days	+
Freon® F 12	100	<=100	7 days	+
fruit juices	technically pure	<=100	7 days	+
Glycerin		<=125	7 days	+
Glycerin		<=150		0
Heptane		<=150	7 days	+
Hydrochloric acid	37	<=150	7 days	+
Hydrofluoric acid	40	<=100	7 days	+
Hydrofluoric acid	70	<= 75	7 days	+
Hydrofluoric acid	100	<= 50	7 days	+
Hydrogen peroxide	50	<=100	7 days	+
Hydrogen sulphide		<=100	7 days	+
Iron-III chloride	50	<=150	7 days	+
Lactic acid	50	23	7 days	+
Lactic acid	50	<= 50	7 days	0
Magnesium chloride	50	<=150	7 days	+
Methanol	technically pure	<= 75	7 days	+
Methanol	technically pure	<=100		0
Methyl ethyl ketone	technically pure	23		-
Methyl isobutyl ketone		23		-

Medium	Concentration (%)	Temperature(°C)	Term	Resistance
Milk		<= 75	7 days	+
Motor oil		<=135	7 days	+
Nitric acid	30	<=125	7 days	+
Nitric acid	30	<=150	7 days	o
Nitric acid	65	<= 60	7 days	+
Nitric acid	65	<=100		o
Nitric acid	98	23		-
Nitrobenzene		23	7 days	+
Nutrient fat		<=100	7 days	+
Paraffin oil		<=120	7 days	+
Perchloroethylene		<= 50	7 days	+
Perchloroethylene		<= 75	7 days	o
Petroleum		<=135		+
Phenol	100	<= 50	7 days	+
Phenol	10	<= 75	7 days	+
Phenol	10	<=100		o
Potassium dichromate	50	<=150	7 days	+
Potassium hydroxide	50	<=100	7 days	+
Potassium hydroxide	50	<=125		o
Potassium nitrate	50	<=150	7 days	+
Potassium permanganate	50	<=150	7 days	+
Propane		<=150	7 days	+
Propanol		<= 50	7 days	+
Salad oil		<=120	7 days	+

Medium	Concentration (%)	Temperature(°C)	Term	Resistance
Silicone oil		<=125	7 days	+
Sodium chlorite	50	<=150	7 days	+
Sodium hydrogen carbonate	50	<=150	7 days	+
Sodium hydroxide	45	<=100	7 days	+
Sodium hydroxide	45	<=125		0
Sodium hydroxide	60	<= 50	7 days	+
Sodium hydroxide	60	<= 75	7 days	+
Sodium hydroxide	60	100		-
Sodium thiosulfate	50	<=150	7 days	+
Sulphur dioxide		<= 80	7 days	+
Sulphuric acid	50	<=150	7 days	+
Sulphuric acid	80	<=125	7 days	+
Sulphuric acid	93	<= 75	7 days	+
Sulphuric acid	98	<= 50	7 days	+
Toluene	technically pure	<= 75	7 days	+
Toluene	technically pure	<=100	7 days	0
Trichloroethylene	technically pure	<= 50	7 days	+
Trichloroethylene	technically pure	<= 75	7 days	0
Water		<=150	7 days	+
Xylene	100	<=100	7 days	+
Zinc chloride	50	<=150	7 days	+

TIPS FOR THE USE OF PVDF

GENERAL INFORMATION

- PVDF is pre shrunk prior to the deposition of electrodes and further “shrinking” is not required
- To bond PVDF to a substrate use a low viscosity epoxy or nitrile contact adhesive. In either case make sure sufficient pressure is applied during cure.
- To cut PVDF use a sharp scalpel

ATTACHING ELECTRODES TO PVDF

GENERAL DISCUSSION

Electrodes can be attached to PVDF in one of two ways:

- conducting adhesive
- mechanical contact.

Soldering to PVDF film is NOT an option for two reasons:

- The heat of the soldering iron is likely to melt the film,
- long before it melts the film the heat will have caused permanent and irreversible damage to the piezo-electric nature of the film. Exposure to temperatures above 80deg C will start to irreversibly degrade the performance of PVDF

To make a connection to the metallised PVDF consider the use of:

- Adhesive connection using silver loaded epoxy
- Mechanical connection via a crimp or fold

CONDUCTIVE ADHESIVE-TYPE SOLUTIONS

There is a wide range of commercially available conduct adhesives, most of which are based upon an epoxy that has been loaded with conductive particulates, with the intention of getting a continuous electrical pathway across adjacent, touching, particulates. Often these adhesives are very heavily loaded with either silver or carbon powders, leading to very low resistances when cured. Unfortunately the adhesive strength of these products is often poor (many of the standard conductive epoxies available from RS or Farnell fall into this category). However the US chemical company Emerson and Cuming make a range of very good conductive adhesives that both bond well and have low resistance; particular recommendations are Eccobond 56c and Eccobond 64c for respectively silver and carbon loaded epoxies. These can be obtained in the UK from Hitek Electronic Materials.

An alternative solution is to form a temporary bond between wire and PVDF film with a cyano-acrylate (Superglue) adhesive and then use silver loaded paint (RS own brand is just fine) over the ends of the wire on the film to make an electrical connection. Once the paint is dry, check the connection with a resistance meter and then re-enforce the connection by applying a small quantity of standard two part clear non-conductive epoxy over the connection.

MECHANICAL CONTACT SOLUTIONS

The other major means of obtaining an electrical contact to PVDF film is to bring the film and the end of the electrode wire into contact and maintaining them there with some form of pressure. This could be accomplished by clamping or crimping an electrode onto the film, or by a lip arrangement as shown below:

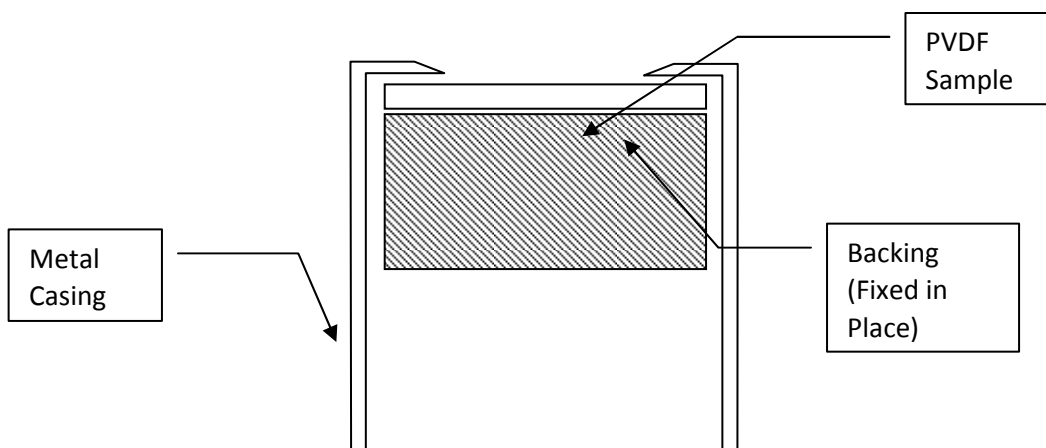

In this particular example the mechanical contact is established between the Metal Casing and the Electrode on the surface of the PVDF sample. The Backing is then pressed onto the rear surface of the PVDF ensuring it is in contact with the metal casing and once in place the backing can be fixed in place by means of a quick setting adhesive.

SPECIFICS FOR BI-MORPH CONFIGURATION

ELECTRODE ATTACHMENT

This should be a combination of both of conductive adhesive and mechanical methods.

ITEMS REQUIRED

- a small length of co-axial wire
- three tagged washers
- small plastic screw with mating nut

METHOD

- Slightly separate a small area of the lamination of the bi-morph along one edge.
- Strip 2 cm of the sheathing away from the co-ax and the braid separated into two portions
- Twist each portion so that two electrodes are formed from the braid of the co-ax.
- Finally strip back 1cm of the core insulator from the co-ax to expose the central core, to leave a total of three electrode leads (one live, two ground).
- Solder the leads onto the tags of the washers as shown in the diagram below. It is important to note that the solder connections are on the outer surfaces of the two braid electrodes.
- Slide the center washer in between the layers of the PVDF laminate with the two washers from the braid electrodes going to the outer surfaces of the Bi-Morph.

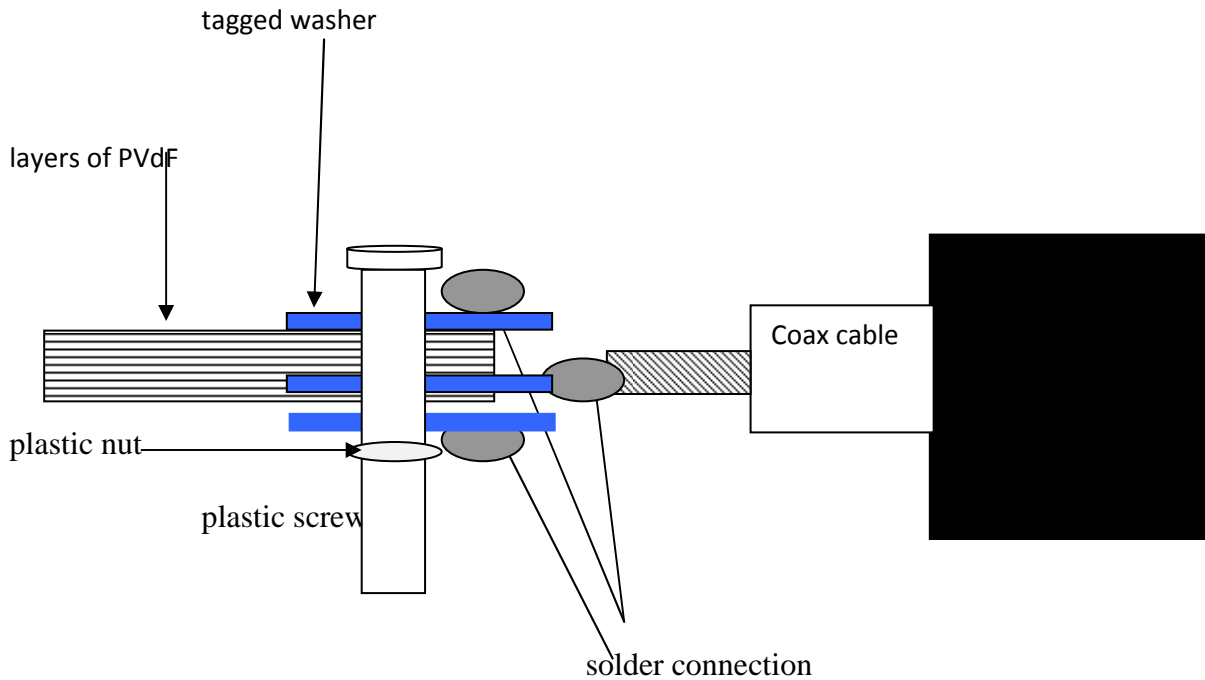

- Make a small hole through laminate such that the plastic screw can be passed all the way through the washers AND the individual sides of the bi-morph.
- Insert the plastic screw and secure with the plastic nut. This ensures a mechanical contact between the three washes and their respective electrodes (two on the outer surfaces, and one on both inner surfaces). The electrodes on the outer surface can then be re-inforced with conductive adhesive (taking care not to allow any to seep through the hole in the laminate and therefore shorting inner and outer electrodes).
- Trim and tidy the connections as necessary.
- Further reinforcement of the joint with non-conductive epoxy can be made as required.